

A TRANSFORMER LESS PV CELL BASED COUPLED INDUCTOR SINGLE STAGE BOOST THREE PHASE INVERTER

Mr. Gaurav Ashok Bongale
ME Student at
Ashokrao Mane Group of Institutions, Wathar, Kolhapur

Prof Mr. P.D.Pange
PG Dean
Ashokrao Mane Group of Institutions, Wathar, Kolhapur

ABSTRACT:

PV cells without transformer in grid connected power system have been attracting many researchers for its smaller volume, lower cost and very higher efficiency as compared to the normal transformer. But while implementing this kind of system one of the biggest technical challenge is issue of leakage current mainly caused by common mode voltages, this leakage current are mainly caused by parasitic capacitors between the solar panel and the ground. In this research article a coupled inductor single stage boost inverter (CL-SSBI) is been implemented. In which introduced an impedance network, this includes the coupled inductor in the front end of the inverter bridge. In this technique uses shoot through zero vectors to store and limit transfer energy within impedance network which will be unique in nature, and it will be utilize for stepping up the bus voltage. Turns ratio of the coupled inductor within the impedance network has designed to improve the boosting voltage. This gives the facility to boost the voltage and also can be regulated over a wide range and step up at higher value is possible. If we adopt higher boost gain scheme then higher power loss and lower efficiency would be unavoidable. However, the transformer less PV system connected to grid based on CLSSBI shows significant reduction in leakage current. A addition of the diode in front of the topology blocks the leakage current.

KEYWORDS: Transformer less grid connected PV cell, CL-SSBI etc.

INTRODUCTION:

A solar energy, particularly in India has a tremendous potential and has been attracting more attention everyday from the system users and for continuous improvement researchers are also concentrating on this issue. The basic advantages of using this are lower cost, smaller volume and higher efficiency. Most difficult task for implementing is the safety issue of leakage current caused by the common mode voltages (CMV) conducting in the loot with parasitic capacitors between the solar panel and the ground. A newly introduced technique coupled inductor single stage boost inverter (CL-SSBI) will generate an impedance network which also includes

the coupled inductor in the starting of the inverter bridge. Using coupled inductor single boost inverter (CL-SSBI) with latest technology like near state pulse width modulation (NSPWM) which may reduce leakage current of the grid connected PV system.

LITERATURE REVIEW:

a) High efficiency single phase transformer less inverters by S.V.Araujo and P.Zacharias: This paper talks about the H-Bridge with a new AC bypass circuit consisting in diode rectifier and a switch with clamping to the DC midpoint to gather very higher efficiencies combining especially with very low amount of ground leakage current.

b) Transformerless inverter for single phase photovoltaic system by R.Gonzalez presented at Mar 2007: This paper talks about when no need for using a transformer in a grid connected photovoltaic (PV) system a galvanic connection between the grid and PV array exists. In these conditions dangerous leakage currents can appear between PV array and ground. leakage current can be avoided by using, different inverter topologies that generate no varying common-mode voltages such as half-bridge and the bipolar pulse width modulation full-bridge topologies.

c) Single stage boost inverter with coupled inductor by Y.Zhou and W.Huang: By introducing impedance network, which even includes coupled inductor into the three phase bridge inverter and adjusting the previously forbidden shoot-through zero state, the converter can realize a high boost gain and output a stable ac voltage. As in power systems distributed generation units often experience big changes in the inverter input voltage due to fluctuations of energy sources. Often a front end boost converter is added to step up the dc voltage when energy resources are at a weak point.

d) Grid connected single phase photovoltaic inverters by I.Patro: Need of a high input voltage represents an important disadvantage of the half bridge, the bipolar PWM full bridge requires a lower input voltage but exhibits a low efficiency.

e) Boost-control methods for the Z-source inverter which can obtain maximum voltage gain at

any modulation index without addition of low-frequency ripple that is related to the output frequency and also reduces the voltage stress. Thus, the Z-network requirement will be independent of the output frequency and determined only by the switching frequency.

f) Eliminating leakage currents in neutral point clamped inverters for photovoltaic system by M. C. Cavalcanti: The main contribution of this paper is the implementation of new modulation techniques for three-phase transformer less star/neutral point of clamped inverters to eliminate leakage currents in photovoltaic systems without need of any modification on the multilevel inverter.

The modulation techniques are capable of handling the leakage currents in photovoltaic systems by applying three medium vectors or using only two medium vectors and one specific zero vectors to compose the reference vector. In addition, to increase the system utilization, the three-phase star or neutral point is fed to clamped inverter can be designed to also provide functions of active filter based on p-q theory. Grid-connected PV single-phase converter is usually employed. It is possible to adopt converter topologies without galvanic isolation between photovoltaic panels and the grid. The absence of a high- or line-frequency transformer permits us to reduce power losses, size of the converter and cost of the converter. On the other side, in the presence of a galvanic connection, a large ground leakage current could arise due to parasitic capacitance of PV panel. Leakage currents cause electric safety problems, electromagnetic interference increase and consequently, a reduction in the converter power quality recent issue of power system technology.

SCOPE OF THE PROPOSED WORK:

If the higher boost is required then higher efficiency & power loss would be unavoidable. This is the disadvantages of single stage boost inverter. As shoot through zero vectors evenly distributed among the three phase legs during the switching period, because conventional system switching frequency is low. The proposed system can be implemented with the help of hardware and the NSPWM technique will be simulated using SIMULINK/MATLAB software. The designed NSPWM technique will be utilized for reducing the leakage current without lowering magnitude of reference voltage. Also the mathematical result will be compared with simulation result.

OBJECTIVES OF PROPOSED WORK:

The objective of proposed “A Transformer less

PV Based Single stage Boost Three phase Inverter System” is as follows-

- Reduce the leakage current caused by common mode voltages in grid connected photovoltaic (PV) system without lowering the magnitude of reference common mode voltages.
- Improve the boost gain for the regulation of wide range of output voltage without increasing the power loss and improve the efficiency of the system.

BLOCK DIAGRAM:

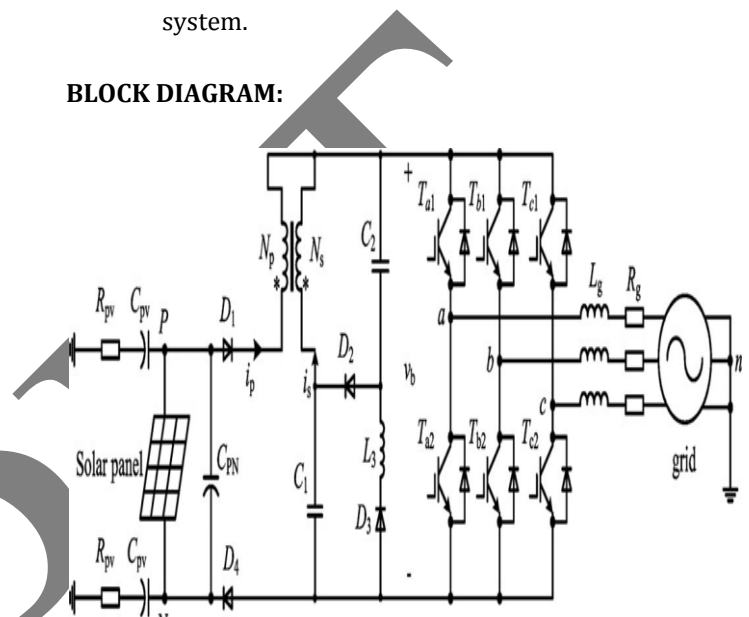

Figure1: Circuit diagram of the implemented system

PROPOSED WORK:

The proposed work as follows:-

1. The input AC supply is given to the driver circuit & ARM Microcontroller.
2. By using PV system the DC voltage will develop.
3. The filter is used to give constant voltage across the PV system.
4. The diode is added in the front of the topology to reduce the leakage current.
5. The PV system is modulated by maximum control boost (MCB).
6. The magnitude of boost control is given to the three phase controlled inverter.
7. The o/p of three phase inverter is given to the grid system.
8. The grid system transmitted the voltage to the distributed substation.

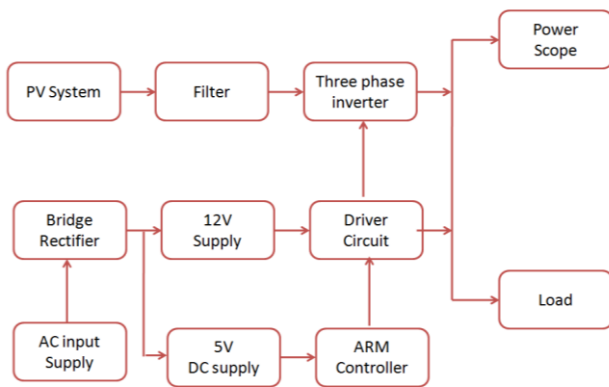

Figure 2: Schematic of the implemented system

ALGORITHM OF THE IMPLEMENTED SYSTEM:

The approach for the proposed project is as follows:-

- Step 1: Collection and study of relevant literature to arrive at central idea of the proposed work.
- Step 2: The system level will be designed as per the system specification.
- Step 3: The each block will be connected and also designed with their specification & functionality.
- Step 4: Also study of coupled- Inductor single stage boost inverter based grid Connected PV system.
- Step 5: By using ARM Microcontroller the gate pulse will be develop.
- Step 6: Study of suitable simulation software (MATLAB/SIMULINK) for validation of controlling system.
- Step 7: The simulation of entire scheme in simulation software to study the various performance such as leakage current, common mode voltage (CMV), zero vectors, open vectors, near state PWM (NSPWM) etc.

- Hardware Requirements:-ARM microcontroller
- Software Requirements:-MATLAB/SIMULINK

CONCLUSION:

System implemented here with both by hardware and Matlab Simulink. For modulation NSPWM technique is used. The implementation of NSPWM technique resulted in reduction in leakage current without altering the amplitude of reference voltage. It is also found the transformer less PV connection grid connection system having major problem of leakage current, it is also reduced to great extent. The implemented system boosts the gain for the regulation over a wide range of output voltage without increasing the power loss for improvement of system efficiency.

REFERENCES:

- [1] R. Gonzalez, J. Lopez, P. Sanchis, and L. Marroyo, "Transformerless inverter for single-phase photovoltaic systems," *IEEE Trans. Power Electron.*, vol. 22, no. 2, pp. 693–697, Mar. 2007.
- [2] H. Xiao and S. Xie, "Transformerless split-inductor neutral point clamped three-level PV grid-connected inverter," *IEEE Trans. Power Electron.*, vol. 27, no. 4, pp. 1799–1808, Apr. 2012.
- [3] S. V Araujo, P. Zacharias, and R. Mallwitz, "High efficiency single-phase Transformerless inverters for grid-connected photovoltaic systems," *IEEE Trans. Ind. Electron.*, vol. 57, no. 9, pp. 3118–3128, Sep. 2010.
- [4] M. C. Cavalcanti, K. C. de Oliveira, A. M. de Farias, F. A. S. Neves, G. M. S. Azevedo, and F. Camboim, "Modulation techniques to eliminate leakage currents in transformerless three-phase photovoltaic systems," *IEEE Trans. Ind. Electron.*, vol. 57, no. 4, pp. 1360–1368, Apr. 2010.
- [5] J. M. Shen, "Novel transformerless grid-connected power converter with negative grounding for photovoltaic generation system," *IEEE Trans. Power Electron.*, vol. 27, no. 4, pp. 1818–1829, Apr. 2012.
- [6] O'. López, F. D. Freijedo, A. G. Yepes, P. Fernández-Comesana, J. Malvar, R. Teodorescu, and J. Doval-Gandoy, "Eliminating ground current in a transformerless photovoltaic application," *IEEE Trans. Energy Convers.*, vol. 25, no. 1, pp. 140–147, Mar. 2010.
- [7] F. Bradaschia, M. C. Cavalcanti, P. E. P. Ferraz, F. A. S. Neves, E. C. dos Santos, Jr., and J. H. G. M. da Silva, "Modulation for three-phase transformerless Z-source inverter to reduce leakage currents in photovoltaic systems," *IEEE Trans. Ind. Electron.*, vol. 58, no. 12, pp. 5385–5395, Dec. 2011.
- [8] X. Guo, M. C. Cavalcanti, A. M. Farias, and J. M. Guerrero, "Single carrier modulation for neutral point-clamped inverters in three-phase transformerless photovoltaic systems," *IEEE Trans. Power Electron.*, vol. 28, no. 6, pp. 2635–2637, Jun. 2013.
- [9] I. Patrao, E. Figueres, F. Gonzalez-Espin, and G. Garcera, "Transformerless topologies for grid-connected single-phase photovoltaic inverters," *Rev.*, vol. 15, no. 7, pp. 3423–3431, Sep. 2011.

[10] D. Barater, G. Buticchi, A. S. Crinto, G. Franceschini, and E. Lorenzani, "Unipolar PWM strategy for transformerless PV grid-connected converters," *IEEE Trans. Energy Convers.*, vol. 27, no. 4, pp. 835–843, Dec. 2012.

[11] M. C. Cavalcanti, A. M. Farias, K. C. de Oliveira, F. A. S. Neves, and J. L. Afonso, "Eliminating leakage currents in neutral point clamped inverters for photovoltaic systems," *IEEE Trans. Ind. Electron.*, vol. 59, no. 1, pp. 435–443, Jan. 2012.

[12] T. Salmi, M. Bouzguenda, A. Gastli, and A. Masmoudi, "Transformerless microinverter for photovoltaic systems," *Int. J. Energy Environ.*, vol. 3, no. 4, pp. 639–650, Jan. 2012.

[13] B. Yang, W. H. Li, Y. J. Gu, W. F. Cui, and X. N. He, "Improved transformerless inverter with common-mode leakage current elimination for a photovoltaic grid-connected power system," *IEEE Trans. Power Electron.*, vol. 27, no. 2, pp. 752–762, Feb. 2012.

[14] B. Gu, J. Dominic, J.-S. Lai, C.-L. Chen, T. LaBella, and B. Chen, "High reliability and efficiency single-phase transformerless inverter for grid connected photovoltaic systems," *IEEE Trans. Power Electron.*, vol. 28, no. 5, pp. 2235–2245, May 2013.

[15] E. Koutroulis and F. Blaabjerg, "Design optimization of transformerless grid-connected PV inverters including reliability," *IEEE Trans. Power Electron.*, vol. 28, no. 1, pp. 325–335, Jan. 2013.