

Paper ID: VESCO-MM28

ACCIDENT PREVENTION AND DETECTION SMART SYSTEM IN AUTOMOBILE

Mali V. D.

Dept. Electronics & Telecommunication
Engineering, V.V.P.I.E.T. Solapur, Maharashtra, India.
vdm9790@gmail.com

Salunkhe S. C.

Dept. Electronics & Telecommunication Engg.
V.V.P.I.E.T. Solapur, Maharashtra India.
sonali240248@gmail.com

Rathod P. L.

Dept. Electronics & Telecommunication
Engineering, V.V.P.I.E.T. Solapur, Maharashtra, India.
push.rathod24@gmail.com

Mr. Mhamane S. C.

Dept. Electronics & Telecommunication
Engineering, V.V.P.I.E.T. Solapur, Maharashtra, India.
sanjeev.mhamane4@gmail.com

Abstract — This paper some methods are discussed how to prevent the accident. Now day lot many accident occurs due to the miss behavior of driver. So avoid this type of problem these system is useful. This system gives warring before the increasing speed of vehicle, change the lane, obstacle is present. With the help of sensor check the some parameter harmful and create accident. This system is also useful for identify accident location by using GPS system and call to police station or hospital by using GSM system. This process is helpful for emergency purpose.

Keywords— Sensor, GPS, GSM, Microcontroller.

1.1 Introduction

Now a day's accident becomes a major problem in our surroundings. So there is a need of anti-collision system. A collision avoidance system is a system of sensors that is placed in a car to warn and controlling action its driver of any dangers that may lie ahead on the road. Some of the dangers that these sensors can pick up on include how close the car is to other cars surrounding.

A situation that provides a good example of how the system works is when a driver is about to change lanes, and there is a car in his blind spot. The sensors will detect that and inform the driver before he starts turning, preventing him from potentially getting into a serious accident. According to the inputs from various sensors warning signals are given to the driver to lower the speed of the car. Also GSM is used to send message to police station or their relative in case of accident occurs.

In this paper the relative speed and distance of all the vehicles around a particular vehicle is estimated using IR sensors and Ultrasonic sensors and based on those results the speed of that particular vehicle is controlled to avoid early collisions. Besides this facility we also provide an accident detection system which detects the accidents and by using GPS and GSM we send the information of the location of the accident place to the police station and relatives, which is most useful information to save the life of person.

1.2 Objective

1. To reduce the point to point harness in vehicle automation.
2. To reduce the no. of accidents.
3. To implement collision Avoidance System (CAS).
4. Automated Accident Detection and Information system (AADIS).

1.3 Hardware Requirements:

a) Ultrasonic Sensor (US020)

It offers excellent range accuracy and stable readings. It is reliable with high accuracy. Working Voltage: DC 5V with the detection range: 2 cm to 700 cm.

b) Alcoholic Sensor (MQ 3)

It is suitable for detecting the alcohol concentration. It has a high sensitivity and fast response time. 5V DC or AC circuit.

c) *Eye Blink Sensor*

It operates on 5 V DC operating voltage, 25 mA supply current. It is digital I/O compatible with optimal sensing distance.

e) *Bump Sensor*

It is basically a switch with a long handle which closes the switch every time it collides with an obstacle. It is of small size simple in working and easy to use.

f) *GSM Module*

For efficient transmission Global System for Mobile communications (GSM) is a very advanced technology. GSM is a very well-known standard for digital mobile communication which is widely used in every part of the world.

i) *GPS Module*

The GPS smart receiver features the 16 channels, Ultra low power GPS architecture. This complete enabled GPS receiver provides high position, velocity and time accuracy performances as well as high sensitivity and tracking capabilities.

1.4 Block Diagram

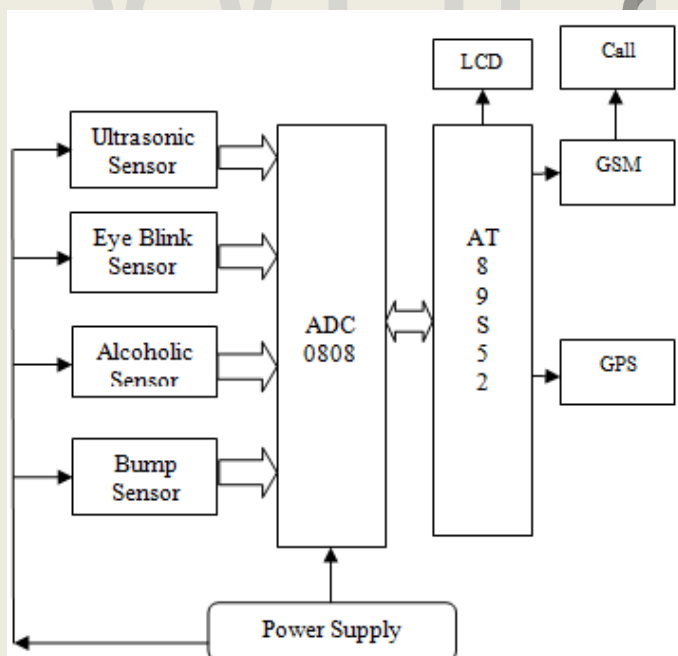

Figure a):- block diagram

1.5 Hardware Assembling and Testing:

First step, we need to make single side PCB layout for the given circuit diagram.

1. Assemble all the components on the PCB based on circuit diagram and insert a valid SIM in the GSM modem.
2. Place the GPS module according to circuit diagram.
3. This implemented and tested successfully by us.
4. This system is very useful and secure for car owners.

1.6 Debugging and Testing Process

A microcontroller-based system is a complex activity that involves hardware and software interfacing with the external world. Doing well design of a microcontroller-based system requires skills to use the variety of debugging and testing tools available. The debugging and testing of microcontroller-based systems divided into two groups: software-only tools and software-hardware tools. Software-only tools come as monitors and simulators, which are independent of the hardware under development. Software-hardware tools are usually hardware dependent, more expensive and range from in-circuit emulators and in-circuit simulators to in-circuit debuggers.

In general, the higher the level of integration with the target hardware, the greater the benefit of a tool, resulting in a shorter development time, but the greater the cost as well. The factors to consider when choosing a debugging tool are cost, ease of use and the features offered during the debugging process. A software simulator is a computer program running on an independent hardware and it simulates the CPU, the instruction set and the I/O of the target microcontroller. Simulators offer the lowest-cost development tools for microcontroller-based systems.

The software program has written in c or assembly language and compiled using Keil software. After compiler operation, the hex code generated and stored in the computer. The hex code of the program should be loaded into the AT89S52. This paper gives a defend way of approaching the problem.

1.7 System Design

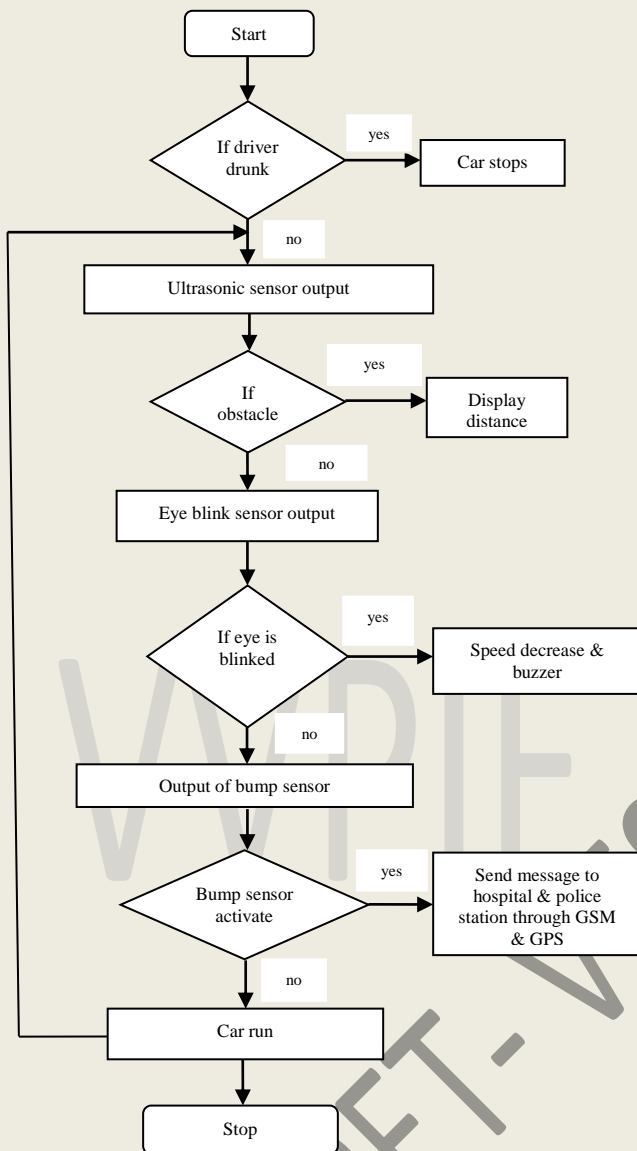

Figure b):-Flow chart

Conclusion:

The main aim of this paper to avoid the most general accidents. If the accident occurred then the accident location can be located easily. This approach the accident is detected by the bump sensor and the information of accident location will be sent to already predefined numbers.

The system has been developed in a special motive that should protect not only the passengers inside the vehicle but also the persons around it results as pedestrians and

also to prevent collision of vehicles with the other vehicle or obstacles such as trees. The developed system is highly helpful to^{yes} prevent accidents which happen around the night time.

Future Scope:

This system could be further enhanced with future technologies to provide further more safety and security to the vehicle systems.

References:

- [1] Li Ran, Wu Junfeng, Wang Haiying, Li Gechen. "Design Method of CAN BUS Network Communication Structure for Electric Vehicle", IFOST 2010 Proceedings IEEE.
- [2] Yujia Wang, Hao Su, Mingjun Zhang., "CAN-Bus-Based Communication System Research for Modular underwater Vehicle", 2011 IEEE DOI 10.1109/ICICTA.2011.
- [3] Chin E. Lin, S. F. Tai, H. T. Lin, T. P. Chen, P. K. Chang, C. C. Kao "Prototype Of A Small Aircraft Avionics Using Hybrid Data Bus Technology" 2005 IEEE
- [4] Chin E. Lin, Hung-Ming Yen, "A Prototype Dual Can-Bus Avionics System For Small Aircraft Transportation System" 2006 IEEE.
- [5] V. Claesson, C. Ekelin, N. Suri, "The event-triggered and time- triggeredmedium-access methods", 6th IEEE International Symposium on Object-Oriented Real-Time Distributed computing, May 14-16, 2003, pp.131-134.