

A REVIEW ON IMPLEMENTATION OF SS- CDMA TRANSMITTER AND RECIEVER SYSTEM BY USING VHDL

Mr. Solwat Kimyanand Bharat ME (Electronics),

ksolwat@gmail.com

Bharat Ratna Indira Gandhi College of Engineering ,Kegaon ,Solapur (MH),India.

Abstract:-

Digital Code Division Multiple Access .In CDMA allows many users to transmit and receive at the same time using a single channel. The transmitter and receiver are synchronized and synthesis carried out using VHDL tool shows increase in the overall speed of the system & the power consumption of the CDMA system will be reduced and error should not be introduce in this system. In past few years, lot of research is performed in both industries and academics into the development of CDMA. In CDMA multiple signal channels occupy the same frequency band being distinguished by the use of different spreading codes. Digital cellular telephone system and personal communication system uses CDMA communication. In this direct sequence spread spectrum principle based code division multiple access (CDMA) transmitter and receiver is implemented in VHDL for FPGA. The Xilinx synthesis technology of Xilinx ISE 9.2i tool will be used for synthesis of transmitter and receiver on FPGA Spartan3E. A transmitter and Receiver components have been designed individually using Bottom-up approach. The designs then are combined and defined by component declaration and port mapping. This work concentrates on application of VHDL simulation and FPGA compiler to Wireless Data components.

KEYWORDS: -CDMA, VHDL, Pseudo-noise (PN),PN sequence generator

I. INTRODUCTION

CDMA technique is based on the spread spectrum Communication. For a spread spectrum signal the Transmission bandwidth is much wider than the bandwidth of the original signal .In a CDMA communication system a unique binary spreading sequence (a code) is assigned for each call to every user & all share the same frequency at the same time. The signal of each user is separated or "de-spread" from the others at the receiver using a correlate key with the associated code sequence. Spreading codes of a spreading sequence can be divided into pseudo-noise (PN) code. PN codes are pseudo-random codes generated by a feedback mechanism using shift registers. In a CDMA transmitter, the information is modulated by a spreading code, and in the receiver it is correlated with a replica of the same code. Thus, low cross-correlation between the desired and interfering users is important to suppress the multiple access interference. Good auto-correlation properties are required for reliable synchronization and reliable separation of the multipath components. Having good auto-correlation properties is also an indication of good randomness of a sequence, which allows us to connect other important sequences properly.

Multiuser detection techniques followed by a technique for efficient use of bandwidth in a wireless communication system. This design method requires less circuitry for implementation and provides better simulation results. The

modulation process, i.e. using binary phase shift keying (BPSK) at the output of transmitter to regenerate the signal strength in its original form after being attenuated by the interferences of several users. Different amount of time delay and attenuation factors provides the multipath diversity, where the diversity order is equal to the number of combined multipath components. The implementation of Transmitter and Receiver side of the circuit was coded using VHDL [6]. In Spread spectrum communication the signal occupies a bandwidth much greater than that which is necessary to send the information. This results in many benefits, such as immunity to interference and jamming and multi-user access. The bandwidth is spread by means of a code which is independent of the data. The independence of the code distinguishes this from standard modulation schemes in which the data modulation will always spread the spectrum somewhat.

The receiver synchronizes to the code to recover the data. The use of an independent code and synchronous reception allows multiple users to access the same frequency band at the same time. In order to protect the signal, the code used is pseudo-random. It appears random, but is actually deterministic, so that the receiver can reconstruct the code for synchronous detection. This pseudo-random code is also called pseudo-noise (PN).

II. MULTIPLE ACCESS TECHNIQUES

Multiple Access method allows many simultaneous users to use the same fixed bandwidth frequency spectrum. For mobile phone systems the total bandwidth is typically 50 MHz, which is split in half to provide the forward and reverse links of the system. Sharing of the spectrum is required in order to increase the user capacity of any wireless network. FDMA, TDMA and CDMA are the three major methods of sharing the available bandwidth to multiple users in wireless system. Among these multiple access techniques CDMA provides less interfered and more secured type communication hence is more important.

A. Frequency Division Multiple Access

In Frequency Division Multiple Access available bandwidth is subdivided into a number of narrower band channels. Each user gets a unique frequency band for transmitting and reception. During a call, no other user can use the same frequency band. Each user is allocated a forward link channel (from the base station to the mobile phone) and a reverse channel (back to the base station), each being a single way link. The transmitted signal on each of the channels is continuous allowing analog transmissions. The channel bandwidth used in most FDMA systems is typically low (30 kHz) and channel only support a single user.

B. Time Division Multiple Access

Time Division Multiple Access (TDMA) divides the available spectrum into multiple time slots, by giving each user a time slot in which they can transmit or receive TDMA systems Transmit data in a buffer and burst method, thus the transmission of each channel is non-continuous. The input data to be transmitted is buffered over the previous frame and burst transmitted at a higher rate during the time slot for the channel. TDMA cannot send an analog signal directly due to the buffering required, thus is only used for transmitting.

C. Code Division Multiple Access

Code Division Multiple Access (CDMA) is a spread spectrum technique that uses neither frequency channels nor time slots. With CDMA, the narrow band message (typically digitized voice data) is multiplied by a large bandwidth signal that is a pseudo random noise code (PN code). All users in a CDMA system use the same frequency band and transmit simultaneously. The transmitted signal is recovered by correlating the received signal with the PN code used by the transmitter. CDMA technology was originally developed by the military during World War II. Researchers were spurred into looking at ways of communicating that would be secure and work in the presence of jamming. Some of the properties that have made CDMA useful are:

Anti-jam and interference rejection

Information security

Accurate Ranging

III. SYSTEM DESIGN

The Code Division multiplexing system consist of a two digital data sources,a multiplexing transmitter and demultiplexing receiver.The system block diagram shown in below

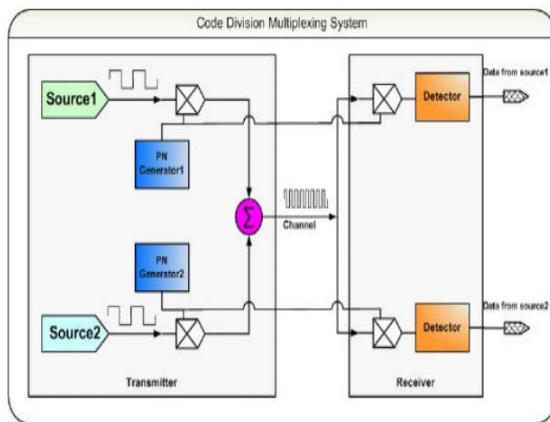

Fig 1: Code division multiplexing system Block diagram

At the transmitter end, two data sources generate digital data sequences which are individually multiplied using two data sequences which are individually multiplied using PN code sequences. Each user is identified by its unique code. The PN code sequences are generated by periodically repeating PN codes at a rate much greater than the source data rate. The modulated sequence hence has wider frequency spectrum than the original sources sequence and is called spread spectrum data sequence. It is imperative that the two codes are orthogonal codes. The PN codes can be used as the orthogonal codes. The PN code sequences can be easily generated using a linear feedback shift register that is a LFSR and is preferred over Wash code for randomness and better spectrum spreading over a common channel.at the receiver end, spread spectrum data sequence received over the common channel is separately multiplied by PN code sequences corresponding to each source on the transmitter side. The detector then uses the multiplied sequence to determine whether the received data is a one or a zero. In the above system, time synchronization between transmitter and receiver

is essential for proper detection.to ensure time synchronization, a single master clock generator is used as reference clock for the entire system. All of the modulation and demodulation techniques strive to achieve greater power and/or bandwidth efficiency in a stationary additive white Gaussian noise channel. Since bandwidth is a limited resource, one of the primary design objectives of all modulation schemes is to minimize the required transmission bandwidth. Spread spectrum techniques on the other hand employ a transmission bandwidth that is several orders of magnitude greater than the minimum required signal bandwidth. While this system is very bandwidth inefficient for a single user, the advantage of spread spectrum technique is that many users can simultaneously use the same bandwidth without significantly interfering with one another. In a multiple-user multiple access interference environment, spread spectrum systems becomes very bandwidth efficient.

Spread Spectrum Communication

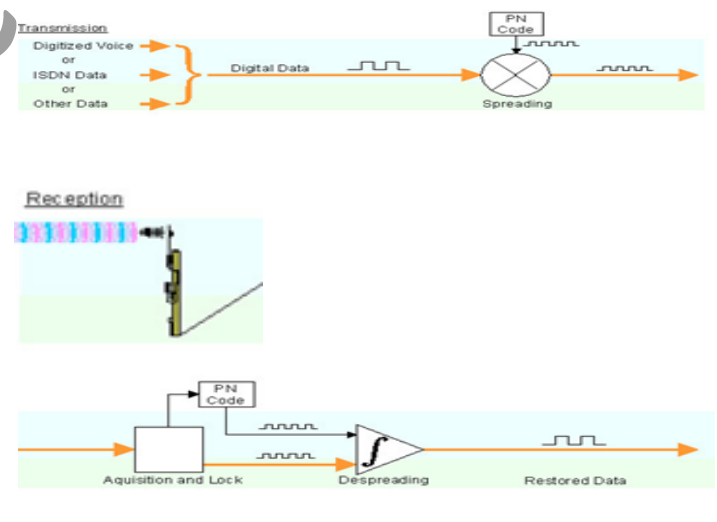

Fig 2: Spread Spectrum Communication

The signal occupies a bandwidth much greater than that which is necessary to send the information. This results in many benefits, such as immunity to interference and jamming and multi-user access. The bandwidth is spread by means of a code which is independent of the data. The independence of

the code distinguishes this from standard modulation schemes in which the data modulation will always spread the spectrum somewhat.

The receiver synchronizes to the code to recover the data. The use of an independent code and synchronous reception allows multiple users to access the same frequency band at the same time. In order to protect the signal, the code used is pseudo-random. It appears random, but is actually deterministic, so that the receiver can reconstruct the code for synchronous detection. This pseudo-random code is also called pseudo-noise (PN).

Design of CDMA transmitter

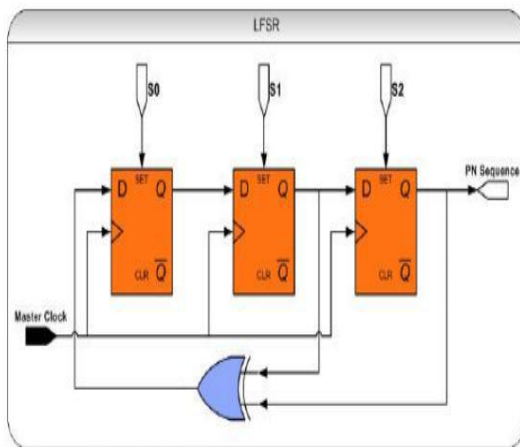

Fig3: Design of CDMA Transmitter

This component implements 7-bit PN code generator using three stages linear feedback shift register (LFSR). The logic diagram of the 3 stages LFSR implement in VHDL is as shown in fig. The two separated PN generator entities were implemented; one each for two sources the bit initialize was set within the VHDL coding itself in each entity.

And in the transmitter the 3-bit input sequence is given then the PN sequence is add in 3-bit data, then main output is obtain at the output of the transmitter and then the output will be addition of S0,S1,S2 and PN sequence then 7-bit output will came and it is given to the receiver. When we gave the input bit 101 & the PN generation should be 1 in the transmitter then in the input bit the PN sequence was

introduced in input bit then the main output was combination of PN sequence & input bit will be 001 then 001 will be transmitted to the receiver from transmitter
PN Sequence Receiver

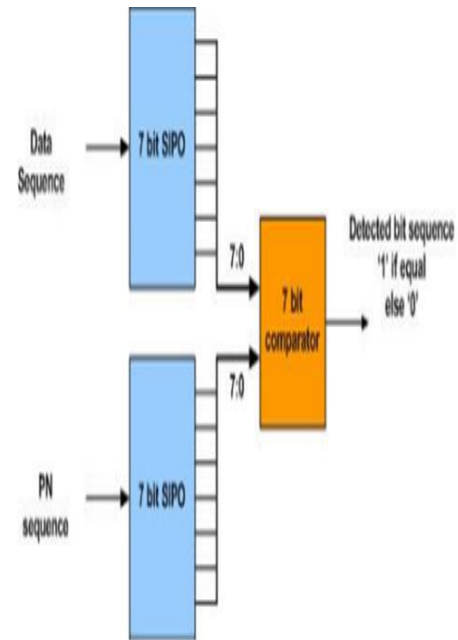

Fig 4: Design of CDMA Receiver

This component implements the detector unit on the receiving side. The component is composed of 7-bit comparator and 7-bit Serial in Parallel out (SIPO) Register. The comparator operates at divide by seven clocks and SIPO operates at master clock rate. The block diagram or receiver component is shown in fig. This is a special component which counts two clock cycles and then asserts its output port high. The component provides the necessary synchronization at output section. then at the receiver the PN sequence and data is differ from each other and input bit S0,S1,S2 Will matched each other and synchronization between transmitter and receiver was done in the CDMA system.

Then at the receiver 001 is the input at the receiver that should be transmitted from transmitter then the PN sequence should be extract from input then then after extracting PN sequences then the main output will be getting

at the output that should be 101 then with the higher security synchronization will be done successfully in this system.

LFSR (Linear feedback shift register)

The LFSR used as CDMA system transmitter in our project it is used to generate PN sequence for CDMA system transmitter.

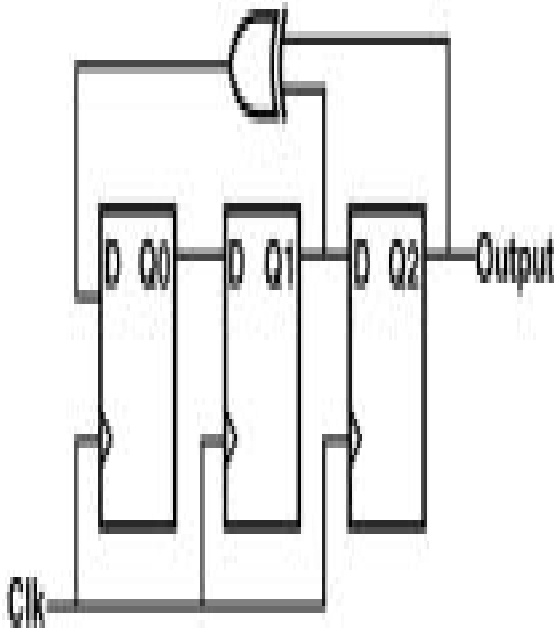

Fig 5: Diagram of LFSR

In the Fibonacci implementation, the outputs from some of the registers are exclusive-ORed with each other and feedback to the input of the shift register. Figure 1 shows a 3-bit Fibonacci LFSR. When the shift register is loaded with a seed value (any value except all zeros) and then clocked, the output from the LFSR (Q2) will be a pseudo-random sequence of 1's and 0's. The length of the pseudo-random sequence is dependent on the length of the shift register and the number and the position of the feedback taps. The number and the position of the taps are commonly represented by a polynomial. For the Xilinx core, this is expressed in the form $(x) = X^3 + X^1 + 1$. For more information on this polynomial notation and how it relates to the LFSR implementation. If XOR is chosen, the all-zeros case can

never be entered from another state, and the core cannot exit an all-zeros state unless Maximum Length Logic is enabled.

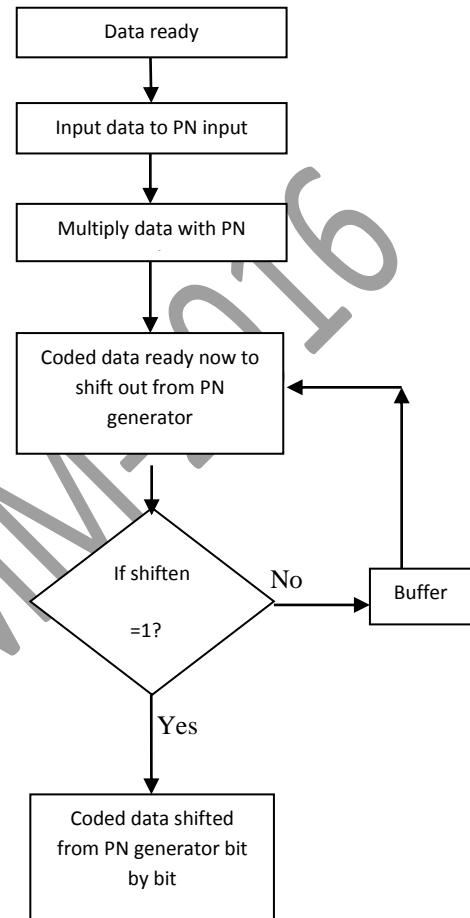

Fig.6. Flow chart of the PN generator

V. APPLICATION

- 1) CDMA system can be used in voice services.
- 2) CDMA system can be uses in data services.
- 3) CDMA system can be uses in Circuit switched data.
- 4) CDMA system can be uses in Message services.
- 5) CDMA system can be uses in Location based services.
- 6) CDMA system can be uses in Wireless communication system.
- 7) CDMA system can be uses as security purpose.

VI. RESULT

A. Output waveform of transmitter

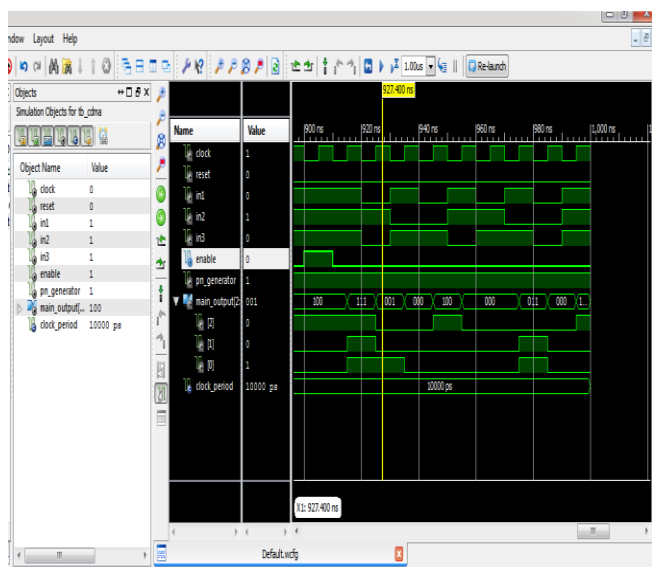

Fig 7: Simulation result for transmitter

B. output simulation waveform of Receiver

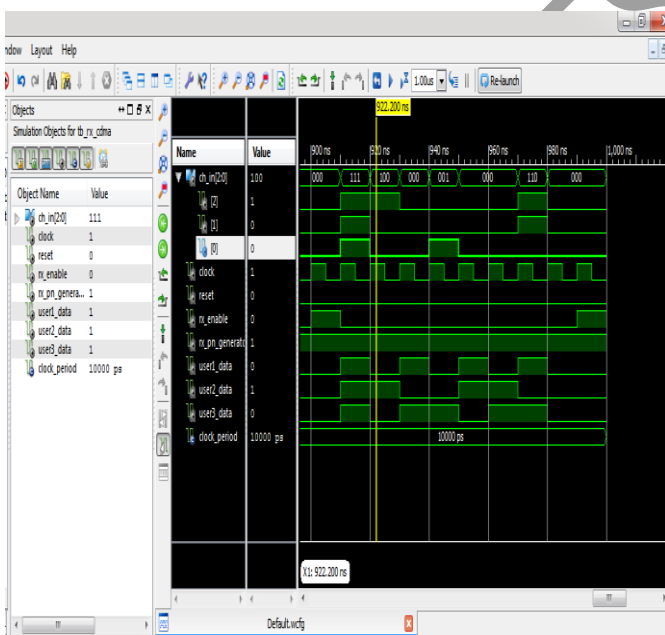

Fig 8: Simulation result for Receiver

VII. CONCLUSION

This design procedure of CDMA achieve the synchronization between transmitter and receiver and the power consumption should be reduced and error should not be introduce in the CDMA system and also for generation of PN sequence is having less number of feedback stages resulting better energy efficiency & data bit should not be hack in this system. Due to adding of PN sequences in input data bit hence the proper synchronization will be takes place in thissystem. Which input bit we will be transmitted from the transmitter that same bit will be came at the output of the receiver hence synchronization will be takes place properly in the CDMA system.

REFERENCES

- [1] Mukhtar Ahmad Wani, M MMushtaq, RoohieNaaz Mir "Implementation of Code Division Multiple Access using Asynchronous Sequential Techniques" International Journal of Computer Applications (0975 – 888) Volume 47– No.9, June 2012.
- [2] SwetaMalviya&PoonamKumari "Implementation of Pseudo-Noise Sequence Generator on FPGA Using Verilog" International Journal of Electronic and Electrical Engineering. ISSN 0974-2174 Volume7, Number 8 (2014), pp. 887-892.
- [3] Gaurav P.Channe, C.N.Bhojar"VHDL implementation of DSSS-CDMA Transmitter and Receiver for AD HOC Network" 13th IRF International Conference, 20th July-2014, Pune, India, and ISBN: 978-93-84209-37-7.
- [4] Vaibhav K Kakade"Implementation of DS-CDMA Transmitter and Receiver in VHDL for FPGA" International Journal of Latest Trends in Engineering and Technology (IJLTET).
- [5] <http://www.google.co.in/xilinx software> 14.2.

- [6] <http://www.academia.edu/DSSS-CDMA> Transmitter and Receiver using VHDL.
- [7] <http://www.scribd.com/CDMA> System implementation using FPGA.
- [8] Viterbi A.J. "CDMA Principles of Spread-Spectrum Communications", Reading, Mass.: Addison-Wesley Publishing Company, 1995.
- [9] J.Bhaskar "Verilog HDL Synthesis a Practical primer" B.S Publication.
- [10] John G. Porkies, "Digital Communication" McGraw-Hill, Third Edition 1995.
- [11] International Journal of Science and Engineering Applications Volume 3 Issue 2, 2014, ISSN-2319-756 optical switching controller using FPGA as a controller for OCDMA encoder system
- [12] International Journal of Electronic and Electrical Engineering. ISSN 0974-2174 Volume 7, Number 8 (2014), pp. 887-892 Implementation of Pseudo-Noise Sequence Generator on FPGA Using Verilog.
- [13] Sreedevi, V. Vijaya, CH. Kranthi Rekh, Rama Valupadasu, B. RamaRao Chunduri, "FPGA implementation of DSSS-CDMA transmitter and receiver for Adhoc Networks." IEEE Symposium on computers and informatics 2011.
- [14] M.K. Simon, D.Divsalar and D.Raphaehi "improved parallel interference cancellation for CDMA" IEEE Trans.Commun..vol. 46 Feb 1998.
- [15] B.S. Tripathi, proff. Monika Kapoor, Jan. 2013 "Review on DS SS CDMA Tx and Rx for Adhoc Network" International Journal of Advances in Engineering & Technology, Vol. 5, Issue 2, pp. 274-279.
- [16] J. Padhye, V. Firoiu, and D. Towsley, "A stochastic model of TCP Reno congestion avoidance and control," Univ. of Massachusetts, Amherst, MA, CMPSCI Tech. Rep. 99-02, 1999.
- [17] Jakes, W. C., Jr. (1994), Microwave Mobile Communications, J. Wiley & Sons, New York, 974; reprinted by IEEE Press, 1994, ISBN 0-7803-1069-1. <http://www.cdg.org>. Accessed on 2 Oct. 2001.