

Automatic Solar Tracking Street Light That Glow on Detecting Vehicle and Human Movement

Shingate Jitendra Dnyandeo

TY EE Dattakala Polytechnic, Bhigwan/MSBTE Maharashtra India

Jarad Saurabh Bapu

TY EE Dattakala Polytechnic, Bhigwan/MSBTE Maharashtra India

Bharane Nanaso Kalyan

TY EE Dattakala Polytechnic, Bhigwan/MSBTE Maharashtra India

Bharane Ganesh Ambadas

TY EE Dattakala Polytechnic, Bhigwan/MSBTE Maharashtra India

UNDER THE GUIDANCE OF

PROF. BENKAR A.R.

Department of Electrical Engineering Dattakala Polytechnic, Bhigwan/MSBTE Maharashtra India

Abstract

We are in the time where energy conservation & use of renewable resources has become a necessity. Thus requirement of methods which are not only highly efficient but also low in energy consumption has greatly increased to keep a check on pollution factor. Keeping this in mind this project focuses on solar based LED street light glow on presence of vehicle and human movement that uses automatic street light controller with a solar tracker. Solar tracker is used so as to track maximum sun energy. People have started moving towards the non-conventional sources of energy in this global warming period. Energy generated from these resources should be used in effective manner. As far as energy consumption of any device is one of the important concerns, the proper utilization has also its own importance. This project represents the street-light structure with the solar tracking for reducing energy-consumption. Basically, it consists of three parts, first trying to comprehend the concept of energy harnessing and then attempting to utilize it in utmost possible way. After that as a part of innovative application about how to optimize the power consumed using different electronics components like charge controller and sensor. Infrared (IR) sensor is used for the concerned project with a purpose of activation of led-street-light only when an object is passing through the subjected peripheral of street-light thereby saving energy for further usage and will be useful to prolong the utilization time of street-light. Solar energy is consumed maximum from sun through proper azimuth angle

adjustment. The main aim of representing this project is to deploy this project on commercial basis in market.

Introduction

The increasing demand of energy, the depletion of fossil fuel reserves, the unexpected events taking place on the international scene (local armed conflicts, natural disasters like earthquakes, tsunamis, floods, hurricanes, etc.) that have the potential to partially cripple the energetic systems, proves that the energy security and diversity is a serious aspect that the mankind should seriously consider when deciding the short and middle term energy policy. The general opinion shared by the most part of the specialists supports the idea that the exclusive dependence on the energy produced from fossil fuels (coal, oil, nuclear, etc.) is hazardous, unsustainable and harmful for the environment here we think of a product which is basically constructed for rural are and especially for a pedestrian purpose.

Automatic Solar Tracking Led Street-Light Using Motion Sensor and Single Axis Control “is the idea we believe to be a design, to get implemented, which can bring a revolution in the street-light usage-concerned fields. In a country like India, where cost effectiveness speaks for itself, we intend to build a design which not only provides low-cost product as an outcome but also uses solar energy in its utmost possible way, given the circumstances .This street

light uses single axis tracker which tracks the path of the sun, for the given elevation angle, and aims to absorb maximum as possible energy from the sun through solar panel to the battery. Another emphasis, in this idea, is given to the proper utilization of street-light i.e. activation of it. An implementation of lighting circuitry is done in such a way, cascaded with PIR sensor that it will turn on lights only when someone is passing through the subjected area. Hence it will save the energy during night time as well absorb energy during daytime. So, a dual-purpose product focuses on low energy consumption along with High energy utilization.

History

A solar tracker is a device that orients a payload toward the sun. Payloads can be photovoltaic panels, reflectors, lenses or other optical devices.

In flat-panel photovoltaic (PV) applications, trackers are used to minimize the angle of incidence between the incoming sunlight and a photovoltaic panel. This increases the amount of energy produced from a fixed amount of installed power generating capacity. In standard photovoltaic applications, it was predicted in 2008-2009 that trackers could be used in at least 85% of

commercial installations greater than 1MW from 2009 to 2012. However, as of April 2014, there is not any data support these predictions.

In concentrated photovoltaic (CPV) and concentrated solar thermal (CSP) applications, trackers are used to enable the optical components in the CPV and CSP systems. The optics in concentrated solar applications accepts the direct component of sunlight light and therefore must be oriented appropriately to collect energy. Tracking systems are found in all concentrator applications because such systems do not produce energy unless pointed at the sun

Sunlight has two components, the "direct beam" that carries about 90% of the solar energy, and the "diffuse sunlight" that carries the remainder - the diffuse portion is the blue sky on a clear day and increases proportionately on cloudy days. As the majority of the energy is in the direct beam, maximizing collection requires the sun to be visible to the panels as long as possible.

The energy contributed by the direct beam drops off with the cosine of the angle between the incoming light and the panel. In addition, the reflectance (averaged across all polarizations) is approximately constant for angles of incidence up to around 50°, beyond which reflectance degrades rapidly

Current trends

These panels can be used to power the traffic lights and streetlights

These can be used in home to power the appliances using solar power.

These can be used in industries as more energy can be saved by rotating the panel

This circuit can be used in real time street lights and highways also.

This can be used for lights in parking areas of industries, hotels, restaurants, etc.

Project

“AUTOMATIC SOLAR TRACKING STREET LIGHT THAT GLOW ON DETECTING VEHICLE AND HUMAN MOVEMENT”.

List of equipment

- Solar panel
- ATmega8 micro controller
- Light Dependent Resistor.
- Stepper Motor.
- ATmega8 microcontroller
- DS1307 IC
- PIR sensor
- LDR
- LCD
- LED array
- D.C.Motor.
- Battery storage.
- Protection circuit.
- Control equipment.
- Inverter

Project cost:

- **Project cost up to Rs- 5000/-**

Working

The Sun tracking solar panel consists of two LDRs, solar panel and stepper motor and ATMEGA8 Micro controller.

Two light dependent resistors are arranged on the edges of the solar panel. Light dependent resistors produce low resistance when light falls on them. The stepper motor connected to the panel rotates the panel in the direction of Sun. Panel is arranged in such a way that light on two LDRs is compared and panel is rotated towards LDR which have high intensity i.e. low resistance compared to other. Stepper motor rotates the panel at certain angle.

When the intensity of the light falling on right LDR is more, panel slowly moves towards right and if intensity on the left LDR is more, panel slowly moves towards left. In the noon time, Sun is ahead and intensity of light on both the panels is same. In such cases, panel is constant and there is no rotation.

The proposed system consists of ATmega8 micro controller, Solar panel, Light Dependent resistors and motor driver IC. ATmega8 is AVR family micro controller. It is based on advanced RISC architecture. It is an 8 bit controller. It has 4KB Flash memory, 512 bytes of EEPROM and 1Kb of SRAM. It has 23 programmable

pins. It supports peripheral features like two 8-bit timers, one 16 bit timer, 6 channel ADC with 10-bit resolution, programmable USART, Serial peripheral interface, 2 wire serial interface, etc.

Solar panel is connected to Stepper motor. Solar panel consists of photovoltaic cells arranged in an order. Photovoltaic cell is nothing but a solar cell. Photo resembles light and voltaic is electricity. Solar cell is made up of semiconductor material silicon. When a light ray from Sun is incident on the solar cell, some amount of energy is absorbed by this material. The absorbed energy is enough for the electrons to jump from one orbit to other inside the atom. Cells have one or more electric field that directs the electrons which creates current. By placing metal contact energy can be obtained from these cells.

Light Dependent Resistors are the resistors whose resistance values depend on intensity of the light. As the intensity of light falling on the LDR increases, resistance value decreases. In dark, LDR will have maximum resistance. LDR will output an analog value which should be converted to digital. This can be done using analog to digital converter. ATmega8 has analog to digital converter internally. It has six ADC channels from ADC0 to ADC5. The two LDRs are connected to ADC pins i.e. PC0 and PC1. ADC conversion is done using successive approximation method.

Stepper motor rotates the panel in a stepwise angle. To drive this motor a driver IC is used. Driver IC amplifies the input voltage and protects the microcontroller from back EMF. Generally, motors generate back EMF. This may damage the controller. The driver IC used is L293D. It has H Bridge internally made up of transistors. This IC has 16 pins. Output pins are connected to the stepper motor pins. Input pins are connected to the controller pins as shown in circuit diagram.

By connecting a battery to the solar panel, one can store the energy generated by the solar cells and this energy can be used when required.

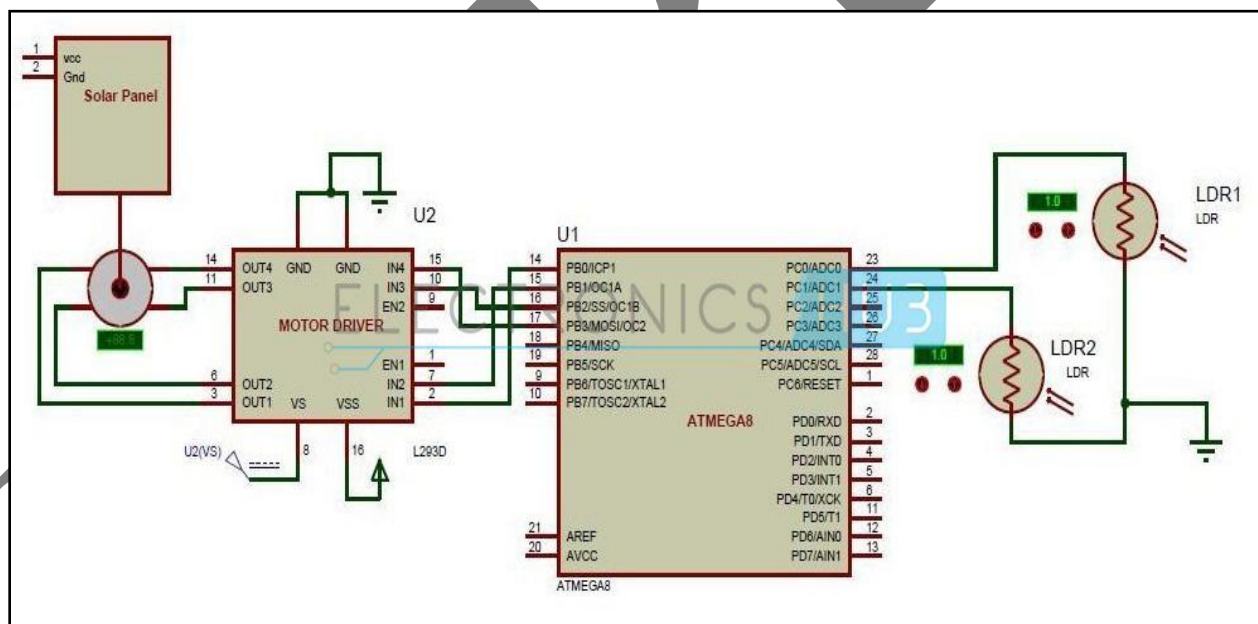

Circuit Diagram for Solar Tracking System

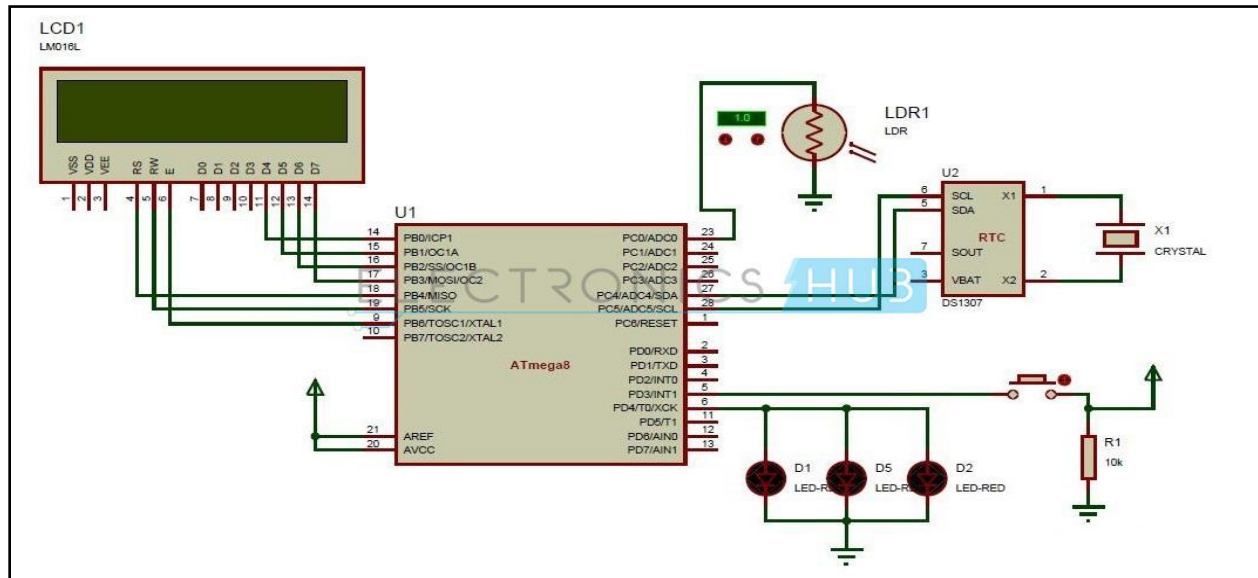

Circuit Diagram for Street Light Glow on Detecting Vehicle Movement

Advantages

- Power wastage can be reduced.
- Using LED array reduces the cost.
- Using of RTC and LDR produces accurate results.
- The solar energy can be reused as it is non renewable resource.
- This also saves money as there is no need to pay for energy used.
- This circuit uses LED Bulbs, so it is very low cost and
- It has more life span.
- Maximum energy can be saved.

Disadvantages

- Though solar energy can be utilized to maximum extent this may create problems in rainy season.

- Although solar energy can be saved to batteries, they are heavy and occupy more space and required to change time to time.
- They are expensive.

Future scope

- Industries
- Street light
- Traffic signals
- Colleges

References

1. www.Electronicshub.Org
2. https://www.youtube.com/watch?feature=player_embedded&v=ElwqJf-R-Cw#t=0
3. <http://www.suntrix.cn/home-en/projects/qindao.aspx>